

# **IEEE Standard Surge Withstand Capability (SWC) Tests for Protective Relays and Relay Systems**

Sponsor  
**IEEE Power System Relaying Committee  
of the  
Power Engineering Society**

Approved October 20, 1988  
Reaffirmed March 17, 1994  
**IEEE Standards Board**

Approved June 5, 1989  
**American National Standards Institute**

---

© Copyright 1989 by

**The Institute of Electrical and Electronics Engineers, Inc.**  
**345 East 47th Street, New York, NY 10017, U.S.A.**

*No part of this publication may be reproduced in any form, in an electronic retrieval system or otherwise, without the prior written permission of the publisher.*

**IEEE Standards** documents are developed within the Technical Committees of the IEEE Societies and the Standards Coordinating Committees of the IEEE Standards Board. Members of the committees serve voluntarily and without compensation. They are not necessarily members of the Institute. The standards developed within IEEE represent a consensus of the broad expertise on the subject within the Institute as well as those activities outside of IEEE which have expressed an interest in participating in the development of the standard.

Use of an IEEE Standard is wholly voluntary. The existence of an IEEE Standard does not imply that there are no other ways to produce, test, measure, purchase, market, or provide other goods and services related to the scope of the IEEE Standard. Furthermore, the viewpoint expressed at the time a standard is approved and issued is subject to change brought about through developments in the state of the art and comments received from users of the standard. Every IEEE Standard is subjected to review at least every five years for revision or reaffirmation. When a document is more than five years old, and has not been reaffirmed, it is reasonable to conclude that its contents, although still of some value, do not wholly reflect the present state of the art. Users are cautioned to check to determine that they have the latest edition of any IEEE Standard.

Comments for revision of IEEE Standards are welcome from any interested party, regardless of membership affiliation with IEEE. Suggestions for changes in documents should be in the form of a proposed change of text, together with appropriate supporting comments.

Interpretations: Occasionally questions may arise regarding the meaning of portions of standards as they relate to specific applications. When the need for interpretations is brought to the attention of IEEE, the Institute will initiate action to prepare appropriate responses. Since IEEE Standards represent a consensus of all concerned interests, it is important to ensure that any interpretation has also received the concurrence of a balance of interests. For this reason IEEE and the members of its technical committees are not able to provide an instant response to interpretation requests except in those cases where the matter has previously received formal consideration.

Comments on standards and requests for interpretations should be addressed to:

Secretary, IEEE Standards Board  
445 Hoes Lane  
P.O. Box 1331  
Piscataway, NJ 08855-1331  
USA

IEEE Standards documents are adopted by the Institute of Electrical and Electronics Engineers without regard to whether their adoption may involve patents on articles, materials, or processes. Such adoption does not assume any liability to any patent owner, nor does it assume any obligation whatever to parties adopting the standards documents.

## Foreword

(This Foreword is not a part of ANSI/IEEE C37.90.1-1989, IEEE Standard Surge Withstand Capability (SWC) Tests for Protective Relays and Relay Systems.)

As the use of semiconductor devices in protective relays and communication equipment increases, so does the need for standard surge tests. Assurance is needed that the relays and relay systems will operate satisfactorily when installed in the harsh environment of a substation or switchyard. Standard surge tests will provide assurance that the relays and relay systems will withstand a specified surge level. The use of proper grounding and shielding techniques when installing the equipment, will assure that the actual surge level impinging on the equipment does not exceed the level to which the equipment was tested.

The first standard document to specify a SWC Test was ANSI C37.90a-1974/ IEEE Std 472-1974 (redesignated ANSI/IEEE C37.90.1-1974), Guide for Surge Withstand Capability (SWC) Tests.

Experience with ANSI/IEEE C37.90.1-1974 was good, and in 1978 the Guide was incorporated as Section 9 of ANSI/IEEE C37.90-1978, Relays and Relay Systems Associated with Electric Power Apparatus. This meant that the oscillatory SWC Test was now a required test for relays and relay systems containing semiconducting devices.

From the beginning, it was realized that the oscillatory SWC test had limitations and did not identify all the problems. The need for a complementary test was recognized and the general type of test required was identified. The problem then became one of a search for a circuit that would produce a repeatable, controllable output. During the search, the IEC “showering arc” test was studied as well as a number of other tests proposed by various organizations. These were all rejected because they were not repeatable or controllable.

The “fast transient” test using the typical test circuit shown was selected, because it was found to be very stable and easy to control. The test can therefore be performed in a minimum time and at a reasonable cost. The typical test circuit has been tried by a number of organizations (relay manufacturers, test equipment manufacturers, utilities, etc.), and found to give good results. In fact, IEC is now trying a similar test circuit.

The addition of the “fast transient” SWC test to the SWC test requirements should identify problems not identified by the oscillatory SWC test alone.

The members of the Digital Processing SWC Requirements Working Group which developed this revision were:

**J. W. Chadwick, Jr., *Chair***

R. W. Beckwith  
H. J. Calhoun  
R. E. Dietrich \*  
E. A. Hauptmann

W. C. Kotheimer \*  
G. Manchur  
A. G. Phadke  
E. A. Udren

S. E. Zocholl  
J. A. Zulaski

Past Chairman\*

The members of the Relay Electrical Environment Subcommittee which reviewed and approved this revision were:

**J. A. Zulaski, *Chair***  
**H. J. Calhoun, *Vice-Chair/Secretary***

J. W. Chadwick, Jr.  
D. C. Dawson  
H. G. Farley  
W. E. Feero  
A. T. Giuliante

E. A. Hauptman  
W. C. Kotheimer  
M. E. Kuczka  
G. J. Marieni  
R. J. Moran

A. G. Phadke  
W. E. Reid  
J. R. Turley  
V. Varneckas

The members of the PES/IEEE Power System Relaying Committee which reviewed and approved this revision were:

**D. R. Volzka**, *Chair*  
**C. H. Griffin**, *Vice Chair*  
**J. R. Boyle**, *Secretary*

J. C. Appleyard	C. M. Gadsden	G. R. Nail
R. F. Arehart	A. T. Giuliante	S. L. Nilsson
C. W. Barnett	S. E. Grier	R. W. Ohnesorge
E. A. Baumgartner	R. W. Haas	G. C. Parr
R. W. Beckwith	R. E. Hart	A. G. Phadke
J. J. Bonk	M. Hirakami	A. C. Pierce
B. Bozoki	R. W. Hirtler	A. Politis
W. D. Breingan	J. W. Ingleson	J. W. Pope
J. A. Bright	R. H. Jones	L. J. Powell
H. J. Calhoun	E. W. Kalkstein	G. D. Rockefeller
J. W. Chadwick, Jr.	T. L. Kaschalk	M. S. Sachdev
D. M. Clark	D. K. Kaushal	E. T. Sage
D. H. Colwell	K. J. Khunkhun	D. E. Sanford
S. P. Conrad	W. C. Kotheimer	L. Scharf
J. Criss	M. E. Kuczka	H. S. Smith
D. C. Dawson	L. E. Landoll	J. E. Stephens
R. W. Dempsey	J. R. Latham	A. Sweetana
H. Disante	J. R. Linders	R. P. Taylor
P. R. Drum	G. J. Marieni	J. R. Turley
L. L. Dvorak	F. N. Meissner	E. A. Udren
W. A. Elmore	J. Miller	C. L. Wagner
J. T. Emery	R. J. Moran	J. E. Waldron
E. J. Emmerling	C. J. Mozina	J. W. Walton
J. Esztergalyos	J. J. Murphy	T. E. Wiedman
W. E. Feero	T. J. Murray	S. E. Zocholl
R. J. Fernandez	K. K. Mustaphi	J. A. Zulaski

When the IEEE Standards Board approved this standard on October 20, 1988, it had the following membership:

**Donald C. Fleckenstein**, *Chair*  
**Marco Migliaro**, *Vice Chair*  
**Andrew G. Salem**, *Secretary*

Arthur A. Blaisdell	John W. Horch	L. Bruce McClung
Fletcher J. Buckley	Jack M. Kinn	Donald T. Michael *
James M. Daly	Frank D. Kirschner	Richard E. Mosher
Stephen R. Dillon	Frank C. Kitzantides	L. John Rankine
Eugene P. Fogarty	Joseph L. Koepfinger *	Gary S. Robinson
Jay Forster *	Irving Kolodny	Frank L. Rose
Thomas L. Hannan	Edward Lohse	Helen M. Wood
Kenneth D. Hendrix	John E. May, Jr.	Karl H. Zaininger
Theodore W. Hissey, Jr.	Lawrence V. McCall	Donald W. Zipse

\* Member Emeritus

CLAUSE	PAGE
1. Introduction .....	1
2. Definition of Terms and Test Wave Shapes .....	1
2.1 Definition of Terms.....	1
2.2 The Oscillatory (SWC) Test Wave Shape and Characteristics.....	2
2.3 Fast Transient SWC Test Wave Shape and Characteristics.....	2
3. Equipment to Be Tested.....	3
3.1 Test Intent .....	3
3.2 System.....	3
3.3 Application.....	3
3.4 Telecommunications .....	3
3.5 Test Points.....	3
4. Application of Test Wave .....	3
4.1 Conditions of the Test.....	3
4.2 Point of Application of SWC Tests.....	4
4.3 Connection Groups .....	5
5. Acceptance, Equipment Changes, Test Data, and Application Notes .....	7
5.1 Acceptance .....	7
5.2 Equipment Changes .....	7
5.3 Test Data .....	7
5.4 Application Notes .....	7
Annex A (Informative) Bibliography .....	9
Annex B (Informative) Typical Test Circuits.....	10
Annex C (Informative) Typical Test Waves.....	11
Annex D (Informative) Fast Transient Repetition Rate.....	12

# IEEE Standard Surge Withstand Capability (SWC) Tests for Protective Relays and Relay Systems

## 1. Introduction

These SWC tests are design tests intended for protective relays and relay systems, including those incorporating digital processors. The application of SWC tests to equipment other than protective relays and relay systems is the responsibility of those specifying the testing.

The oscillatory and fast transient SWC tests are presented as distinct tests in the following section. However, it is not intended to prohibit a combined test, provided all requirements of the individual SWC tests are met.

## 2. Definition of Terms and Test Wave Shapes

### 2.1 Definition of Terms

Certain terms, defined below, are used in surge testing and to identify parts of a relay system. Other terms used are defined elsewhere, such as ANSI/IEEE Std 100-1988, IEEE Standard Dictionary of Electrical and Electronics Terms or ANSI/IEEE C37.100-1981, Definitions for Power Switchgear.<sup>1</sup>

**common-mode voltage:** The voltage which, at a given location, appears equally and in phase from each. signal conductor to ground.

**current circuit.:** An input circuit to which is applied a voltage or a current which is a measure of primary current.

**digital data circuit:** Any circuit that transfers data in a digitally encoded form which is essential for the proper operation of the relay system.

**measuring unit:** Any analog or digital device which analyzes input currents or voltages or both to produce an output to the relay logic.

---

<sup>1</sup>ANSI/IEEE publications are available from the IEEE Service Center, The Institute of Electrical and Electronics Engineers, 445 Hoes Lane, P.O. Box 1331, Piscataway, NJ 08855-1331; or from the Sales Department, American National Standards Institute, 1430 Broadway, New York, NY 10018.

**output circuit:** A circuit from a relay system which exercises direct or indirect control of power apparatus such as tripping or closing of a power circuit breaker.

**power supply circuit:** An input circuit to a relay system which supplies power for the functioning of the relay system.

**relay logic:** A logic network which coordinates the output of measuring units and other inputs to energize output circuits when prescribed conditions and sequences have been met.

**relay system:** An assembly usually consisting of current and voltage circuits, measuring units, logic, and power supplies to provide a specific relay scheme such as line, transformer, bus, or generator protection. A relay system may include interfaces with other systems such as data logging, alarm, telecommunications, or other relay systems.

**signal circuit:** Any circuit other than an input voltage circuit, input current circuit, power supply circuit, or an output circuit.

**surge ground:** The point of external connection to the relay system reference or common bus for surge protection.

**telecommunications interface equipment:** A portion of a relay system which transmits or receives information from a telecommunications system; eg, audio tone equipment or carrier transmitter-receiver included as an integral part of the relay system.

**telecommunications system:** Any of the telecommunication media; eg, microwave, power-line carrier, wire line.

**transverse- (differential-) mode voltage:** The voltage between two conductors of a circuit at a given location.

**voltage circuit:** An input circuit to which is applied a voltage or a current which is a measure of primary voltage.

## 2.2 The Oscillatory (SWC) Test Wave Shape and Characteristics

The oscillatory SWC test wave is an oscillatory wave, frequency range of 1.0 MHz to 1.5 MHz, voltage range of 2.5 kV to 3.0 kV crest value of first peak, envelope decaying to 50% of the crest value of the first peak in not less than 6  $\mu$ s from the start of the wave. The source impedance shall be from 150 to 200  $\Omega$ . The test wave is to be applied to a test specimen at a repetition rate of not less than 50 tests per second for a period of not less than 2.0 seconds. (All voltage and time values refer to the open circuit condition of the generator.)

NOTE — The relative phase of the test wave and the power-system frequency may be a factor to be considered in the application of the test wave when the repetition rate is synchronous to the power-system frequency.

## 2.3 Fast Transient SWC Test Wave Shape and Characteristics

The fast transient SWC test wave is a unidirectional wave. Its rise time, from 10 to 90%, shall be 10 ns maximum. The crest duration above 90% shall be at least 50 ns. The decay time, from crest to 50% of crest value, shall be 150 ns  $\pm$  50 ns. The crest voltage is between 4 kV and 5 kV, open circuit. The source impedance during the initial rise time is 80  $\Omega$  or less. The test wave is applied for not less than 2 seconds at a repetition rate of not less than 50 pulses per second. Pulses of both polarities are to be applied. (All voltage and time values refer to the open circuit condition of the generator.)

NOTE — The relative phase of the test wave and the power system frequency may be a factor to be considered in the application of the test wave when the repetition rate is synchronous to the power-system frequency.

### **3. Equipment to Be Tested**

#### **3.1 Test Intent**

The tests described herein are design tests to be applied to a complete relay system under simulated operating conditions. It is not the intent to test an isolated subassembly of the relay system.

#### **3.2 System**

The composition of a relay system will vary from a single relay mounted on a panel to several equipments integrated into a single relay system. A relay system may also include telecommunications interface equipment such as a carrier transmitter/receiver or audio tone equipment. The user and the manufacturer must agree on what constitutes the relay system to be tested.

#### **3.3 Application**

These tests are design tests not intended to be applied to production relay systems unless specified by the user or as part of general testing by the manufacturer. It is the intent of these tests to prove that a given relay system can operate satisfactorily without component failure and without misoperating when subjected to transients encountered in control wiring.

#### **3.4 Telecommunications**

When telecommunications systems are involved, the points of connection between the relay system and the telecommunications system must be determined. Once determined, the relay system side of the connections to the telecommunications system shall be tested.

#### **3.5 Test Points**

With the relay system defined, all points of connection between the relay system and external circuits shall be tested.

### **4. Application of Test Wave**

#### **4.1 Conditions of the Test**

The tests shall be made under usual service conditions in accordance with ANSI/IEEE C37.90-1978, Relays and Relay Systems Associated with Electric Power Apparatus.

##### **4.1.1 Partial Simulation**

Since the SWC tests are design tests of the relay system, it is important to duplicate as nearly as is feasible the actual in-service conditions. Where portions of the relay system are manufactured by someone other than the relay manufacturer and assembled by the user, those portions may be simulated for the relay system test. In this case, the user shall be responsible for any additional tests on the complete relay system.

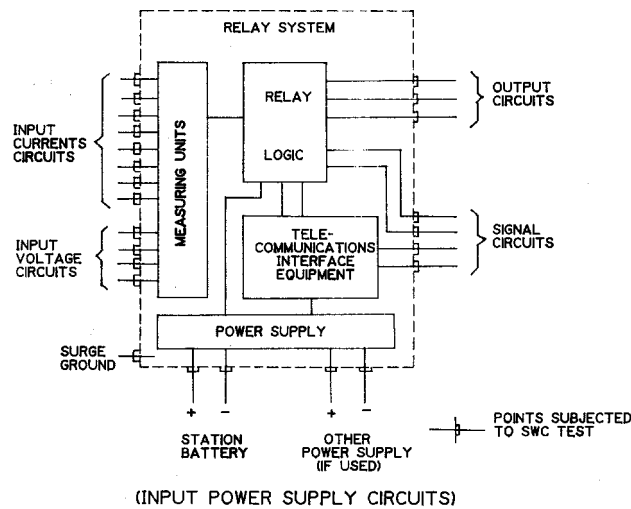

**Figure 1—General Makeup of a Relay System with Communications Interface Showing Points to Be Subjected to SWC Tests**

#### 4.1.2 Circuit Groups

All external connections to the relay system shall be considered in one of the following six groups:

- Current circuits
- Digital data circuits
- Output circuits
- Power supply circuits
- Signal circuits
- Voltage circuits

#### 4.1.3 Voltage and Current Values

It is the intent of this test to duplicate as nearly as possible in-service conditions with the relay in its normal non-transitional state. Where appropriate, the relay system shall be energized with rated voltage and with current equal to 75% of the nominal CT rating. The relay settings should be chosen such that the relay is as close as possible to its transitional state, but not closer than the recommended margins for its application function. Input voltage to power supply circuits must be within specified limits.

#### 4.2 Point of Application of SWC Tests

Figures 1 and 2 show specific points of application as related to the relay system configuration. Tests at these points of application are considered the minimum requirements for equipment used in relay systems.

Details of the recommended method of applying the common mode and transverse mode tests are shown in Figs 3 and 4, respectively, and are discussed in 4.3.

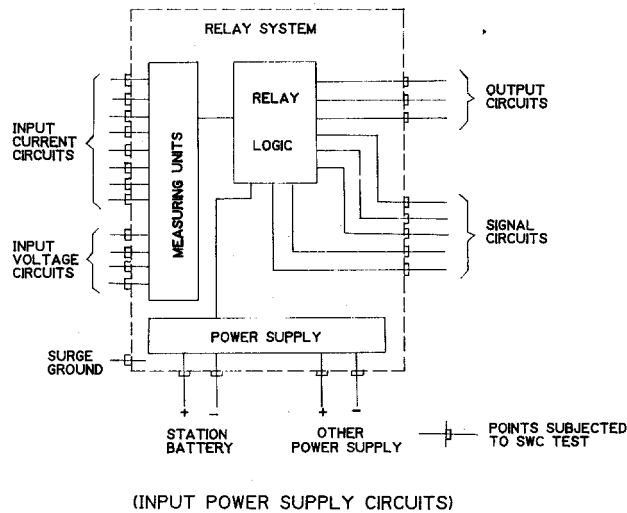

**Figure 2—General Makeup of a Relay System without Communications Interface Showing Points to Be Subjected to SWC Tests**

### 4.3 Connection Groups

Each of the six groups is tested with system conditions as specified in 4.1.

#### 4.3.1 Signal Circuit Tests

Signal circuits shall be tested as follows:

##### 4.3.1.1 Common-Mode Test

The common mode test is required. One terminal of the test generator shall be connected to each connection, or logical group of connections, as shown in Fig 3. The other terminal of the test generator shall be connected to the surge ground of the system.

##### 4.3.1.2 Transverse (Differential) Mode Test

The transverse test is required unless the reason for its exclusion is stated in writing by the manufacturer. The terminals of the test generator shall be connected to the terminals of a signal circuit as shown in Fig 4.

#### 4.3.2 Current Circuit Tests

The common mode test is required. Current circuits of a like group (ie, phase 1, phase 2, phase 3) should be connected via suitable coupling to one terminal of the test generator as shown in Fig 3. The other terminal of the test generator shall be connected to the surge ground of the system. If the current circuit has provision for the circuit residual current to pass through an electrically separate circuit of the relay, then these connections shall also be tested as a part of this current group. In a similar manner, each group of current circuits, such as polarizing circuits, shall be tested.

#### 4.3.3 Voltage Circuit Tests

The common mode test is required. Voltage circuits of a like group (ie, phase 1, phase 2, phase 3) should be connected via suitable coupling to one terminal of the test generator. The other terminal of the test generator shall be connected to the surge ground of the system. In a similar manner, each group of voltage circuits, such as polarizing circuits, shall be tested.

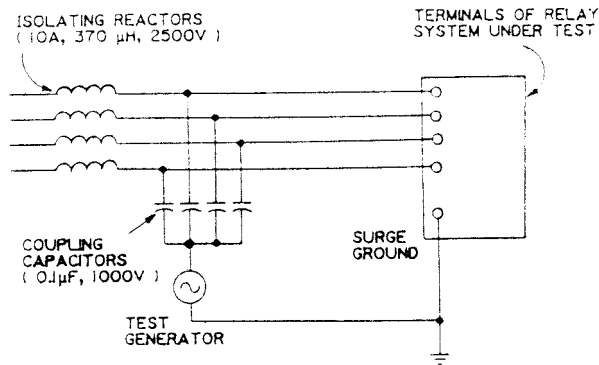

**Figure 3—Application of Common Mode Tests and Typical Component Values**

#### 4.3.4 Power Supply Tests

Each power supply circuit shall be surge tested as a unit.

##### 4.3.4.1 Common-Mode Tests

Connections for these tests shall be as shown in Fig 3.

##### 4.3.4.2 Transverse-Mode Tests

Connections for these tests shall be as shown in Fig 4.

#### 4.3.5 Tests on Output Circuits

Output circuits shall be tested as follows:

NOTE — Some output circuits (eg, relay contacts) may not require surge protection; however, they shall be tested even though their only link to the system is through coupling to adjacent wiring and components.

##### 4.3.5.1 Common-Mode Test

One terminal of the test generator shall be connected to each output connection, or logical group of connections. The other terminal of the test generator shall be connected to the surge ground of the system.

##### 4.3.5.2 Transverse-Mode Test

One terminal of the test generator shall be connected to one output connection of a pair or logical group and the other terminal of the test generator shall be connected to another output connection of a pair or logical group. The test shall be repeated for other pairs until each pair has been tested.

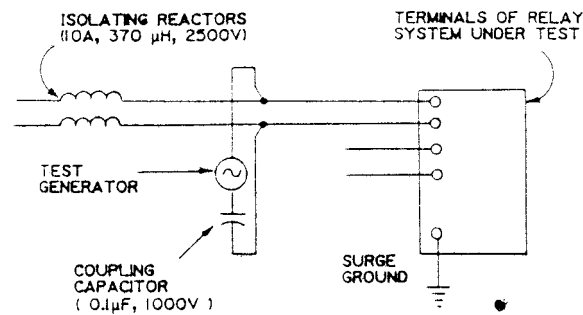

Figure 4—Application of Transverse Mode Tests and Typical Component Values

#### 4.3.6 Digital Data Circuit Tests

Because digital data circuits are affected by the presence of the coupling capacitor and isolating reactor, the tests and method of testing these circuits shall be agreed upon by the user and manufacturer.

## 5. Acceptance, Equipment Changes, Test Data, and Application Notes

### 5.1 Acceptance

A test is successful when no erroneous output is present, no component failure occurs, and there is no change in calibration exceeding normal tolerances. An erroneous output is false information such as target lights, trip pulses, or loss of digital pulse synchronization (when it affects externally-observed relay or relay system behavior).

### 5.2 Equipment Changes

SWC tests shall be required following significant equipment (hardware or software) design changes.

### 5.3 Test Data

A copy of open circuit voltage waveform, short-circuit current waveform, details of the surge generator circuit, and a description of the tests conducted, including relay settings used and operating conditions or applied inputs, shall be supplied on request.

### 5.4 Application Notes

#### 5.4.1 User/Manufacturer Responsibilities

It must be emphasized that the user and the manufacturer both have a responsibility in the control of surges in protection and control circuits. The user has a responsibility to keep the surges presented to the protective relays and relay systems to no more than the surge withstand test values. The user does this by the use of proper installation practices that provide adequate shielding and grounding. The manufacturer has a responsibility to design, manufacture, and test the equipment to meet all the requirements of the surge withstand tests.

### **5.4.2 Surge Ground/Station Ground Connection**

When the relay system is installed in the station, the connection of the surge ground to the station ground must be of sufficient surface area and follow a direct path. This connection must be a low impedance path for high-frequency currents which tend to travel on the surface of the conductor.

## Annex A Bibliography

### (Informative)

- [1] SONNEMANN, W. K. *A Laboratory Study of High-Voltage High-Frequency Transients*. presented at the Texas A&M Protective Relay Conference, April 1965.
- [2] SONNEMANN, W. K. and MARIENI, G. J. *A Review of Transient Voltages in Control Circuits*. Presented at the Relay Committee Meeting, Pennsylvania Electric Association, February 1967.
- [3] SUTTON, H. J. Transients Induced in Control Cables Located in EHV Substation. *IEEE Transactions on Power Apparatus and Systems*, Vol PAS-89, No 6, pp 1069–1081, July/August 1970.
- [4] DIETRICH, R. E., RAMBERG, H. C., and BARBER, J. C. Protection Against Electromagnetic Interference. *Transmission and Distribution*, February 1974.
- [5] BULL, H. H. Susceptibility of Electronic Equipment to Voltage Spikes. *IEE Conference on Developments in Power System Protection*, London, March 1975.
- [6] WISZNIEWSKI, A., and MARCZONEK, S. Transverse Transient Overvoltages and Signal to Noise Ratio of Secondary Protection Wiring. *IEE Conference on Developments in Power System Protection*, London, March 1975.
- [7] VITINS, M. Transient Phenomena in High Voltage Networks and Their Influence on the Design of Protection Equipment. *Brown Boveri Review*, Vol 65, No 6, pp 358–363, June 1975.
- [8] HARVEY, S. M., and PONKE, W. J. Electromagnetic Shielding of a System Computer in a 230-kV Substation. *IEEE Transactions on Power Apparatus and Systems*, Vol PAS-95, No 1, pp 187–196, January/ February 1976.
- [9] WISZNIEWSKI, A. and MARCZONEK, S. Transverse Interference Voltages on Secondary Protection Wiring at Substations. *IEEE Transactions on Power Apparatus and Systems*, Vol PAS-96, No 1, pp 261–267, January/February 1977.
- [10] KOTHEIMER, W. C. and MANKOFF, L. L. Electromagnetic Interference and Solid-State Protective Relays. *IEEE Transactions on Power Apparatus and Systems*, Vol PAS-96, No 4, pp 1311–1317, July/August 1977.
- [11] MESSER, L. A and SAWYER, N.J. Control EMI from Power Supplies. *Electronic Design*, Vol 26, No 4, pp 84–91, February 1978.
- [12] IEEE Std 525-1978, IEEE Guide for Selection and Installation of Control and Low-Voltage Cable Systems in Substations.
- [13] POSPISIL, P. Interference Pulse Voltage in Secondary Measuring and Ancillary Circuits in EHV Substations. *Energetika (Czechoslovakia)*, Vol 28, No 10, pp 432–438, October 1978.
- [14] EPRI Report EL-2982 “Measurement and Characterization of Substation Electro-magnetic Transients.” Project 1359-2, Final Report, March 1983. EPRI, Palo Alto, California.

## Annex B Typical Test Circuits

(Informative)

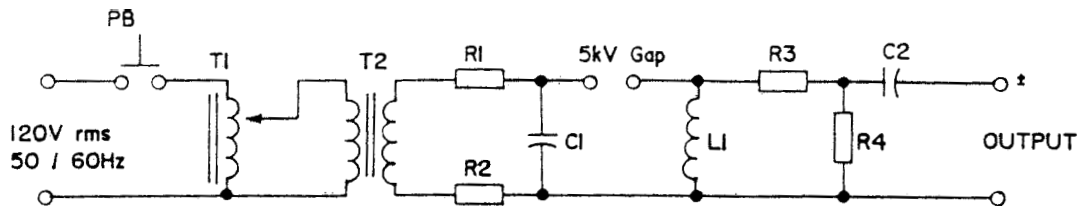

T1, 120V VARIABLE TRANSFORMER, 100VA

T2, 120V - 7200V, 100VA

L1, 0.75 $\mu$ H, 3 TURNS OF 3 / 8 INCH DIAMETER SOFT COPPER TUBING ON 2-1 / 2 INCH DIAMETER FORM.

GAP, POLISHED STEEL BALL BEARINGS ABOUT 5 / 8 INCH DIAMETER.

(NOTE: A MORE CONSISTENT BREAKDOWN IS OBTAINED IF THE SPHERES ARE ILLUMINATED BY ULTRAVIOLET LIGHT. SUITABLE SMALL UV LAMPS ARE AVAILABLE.)

R1 & R2, 100k $\Omega$ , 40 W EACH.  
(USE 20-5 k $\Omega$ , 2 W CARBON COMPOSITION RESISTORS IN SERIES FOR EACH.)

R3 & R4, EACH 300  $\Omega$ , 25 W NON-INDUCTIVE WIREWOUND, NI TYPE.

C1, 0.015  $\mu$ F, 10 kV, MICA TRANSMITTING TYPE.

C2, 0.1  $\mu$ F, 2kV, CERAMIC.  
(TO BLOCK POWER FEEDBACK.)

Figure B.1—Typical Oscillatory SWC Test Circuit

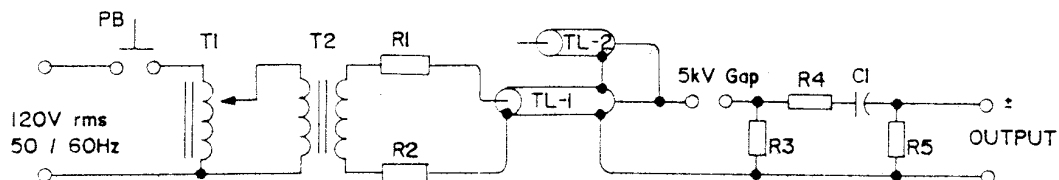

T1, 120V VARIABLE TRANSFORMER, 100VA

T2, 120V - 7200V, 100VA

TL-1, 30-40 FEET RG-58-AU COAXIAL CABLE  
(CONTROLS PULSE WIDTH, LENGTH DEPENDS ON VELOCITY OF PROPAGATION OF CABLE.)

TL-2, 18 INCHES RG-58-AU COAXIAL CABLE  
(CONTROLS RISE TIME OF PULSE.)

GAP, POLISHED STEEL BALL BEARINGS ABOUT 5 / 8 INCH DIAMETER.

(NOTE: A MORE CONSISTENT BREAKDOWN IS OBTAINED IF THE SPHERES ARE ILLUMINATED BY ULTRAVIOLET LIGHT. SUITABLE SMALL UV LAMPS ARE AVAILABLE.)

R1 & R2, 2.5 M $\Omega$ , 10W (USE 10-250 k $\Omega$ , 1W CARBON COMPOSITION RESISTORS IN SERIES FOR EACH.)

R3, 110  $\Omega$ , 1W CARBON COMPOSITION.

R4, 51  $\Omega$ , 1W CARBON COMPOSITION.

R5, 1M  $\Omega$ , 1W CARBON COMPOSITION.

C1, 0.05  $\mu$ F, 1kV CERAMIC DISK.

Figure B.2—Typical Fast Transient SWC Test Circuit

### Annex C Typical Test Waves

(Informative)

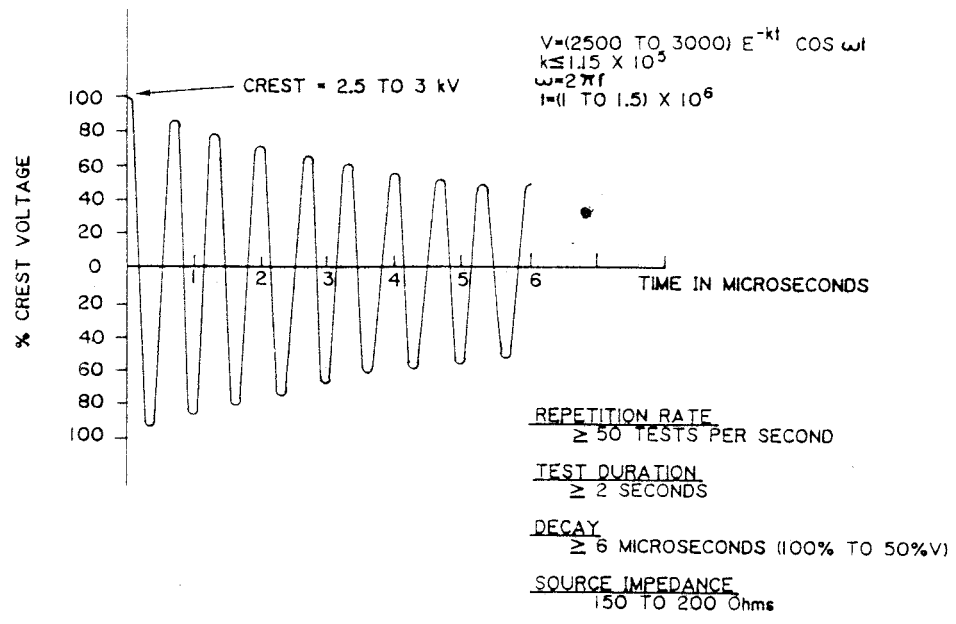

Figure C.1—Typical Oscillatory SWC Test Wave (Open Circuit)

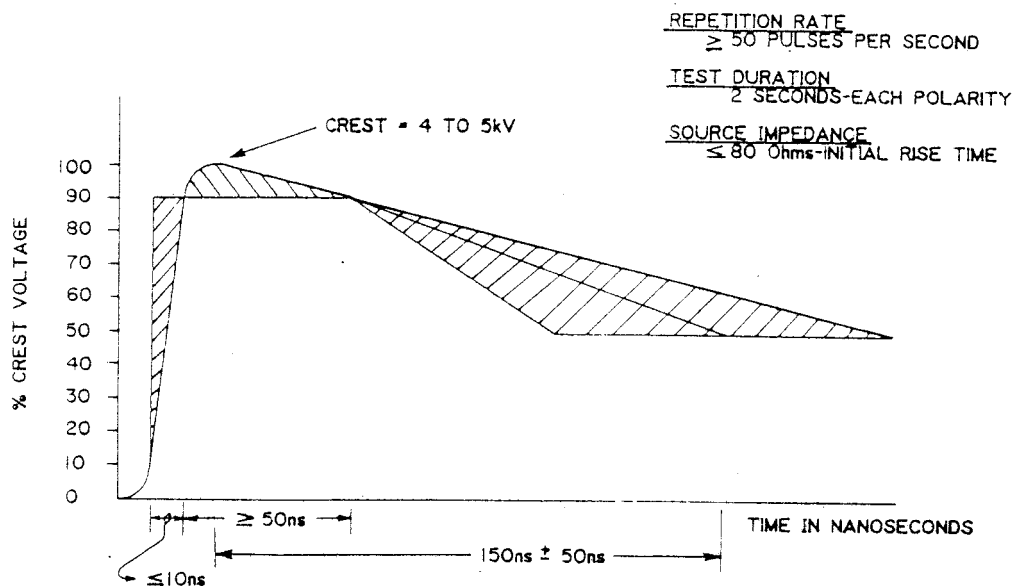

Figure C.2—Typical Fast Transient SWC Test Wave (Open Circuit)

## **Annex D Fast Transient Repetition Rate**

### **(Informative)**

The coil of an auxiliary relay, tightly wound with many thousands of turns of wire, can have inductance of tens of henries as well as equivalent shunt capacitance of 500 to 1000 picofarads. When the contacts of a controlling circuit open to de-energize such a coil, the initial interruption produces a fast-rising recovery voltage which breaks down the dielectric of the contact gap once again. The resulting flashover collapses the recovery voltage so that interruption occurs once again. As the contacts part, a series of restrikes and interruptions occur, with increasing recovery voltage each time, until the gap finally withstands the maximum recovery voltage which the coil can produce.

Each time the recovery voltage builds up, the stray capacitance across the coil is charged. When the following restrike occurs, the stored energy is discharged into the connected control circuit and produces a fast transient voltage which is readily coupled to other nearby circuits. Protective relays connected to such circuits must withstand the rate of rise for the last and largest of these voltage transients without misoperation or damage.

The number and frequency of these impulses depends on specific factors at each installation. Each fast-transient test impulse, as specified in this document, simulates only the single largest expected impulse, not the entire series of impulses.

The minimum repetition rate and test duration have been selected to subject the relay under test to a series of pulses in each direction. This simulates the fast voltage transients generated by a number of relay coils which are interrupted in rapid succession, such as might occur for a fault which leads to a complex series of control actions.